

HELLWIG

SUSPENSION ACCESSORIES

16237 AVENUE 296 . VISALIA, CA 93292
TEL. (559) 734-7451 1-800-435-5977 FAX (559) 734-7460

INSTALLATION INSTRUCTIONS REAR STABILIZER BAR

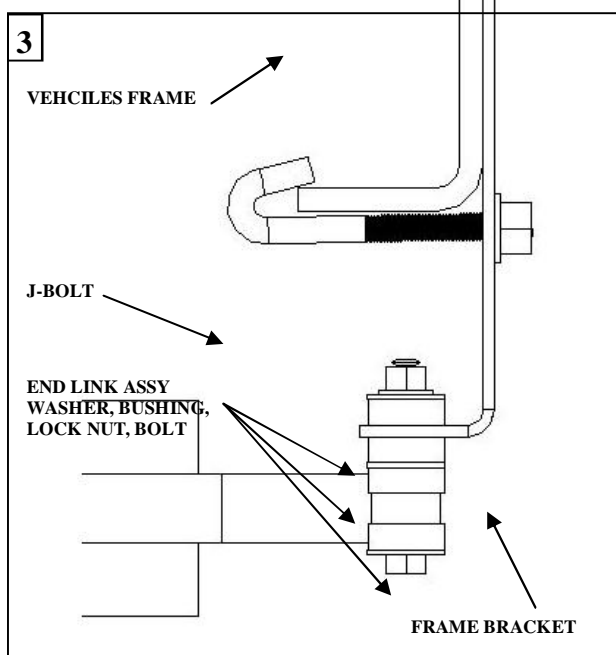
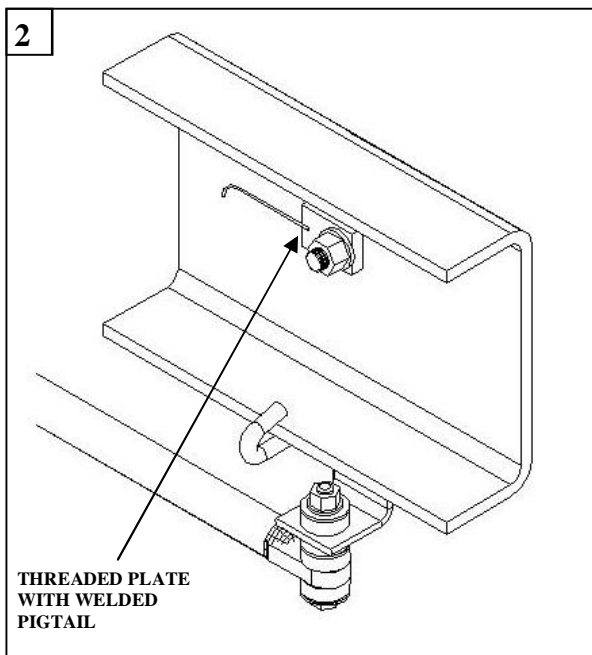
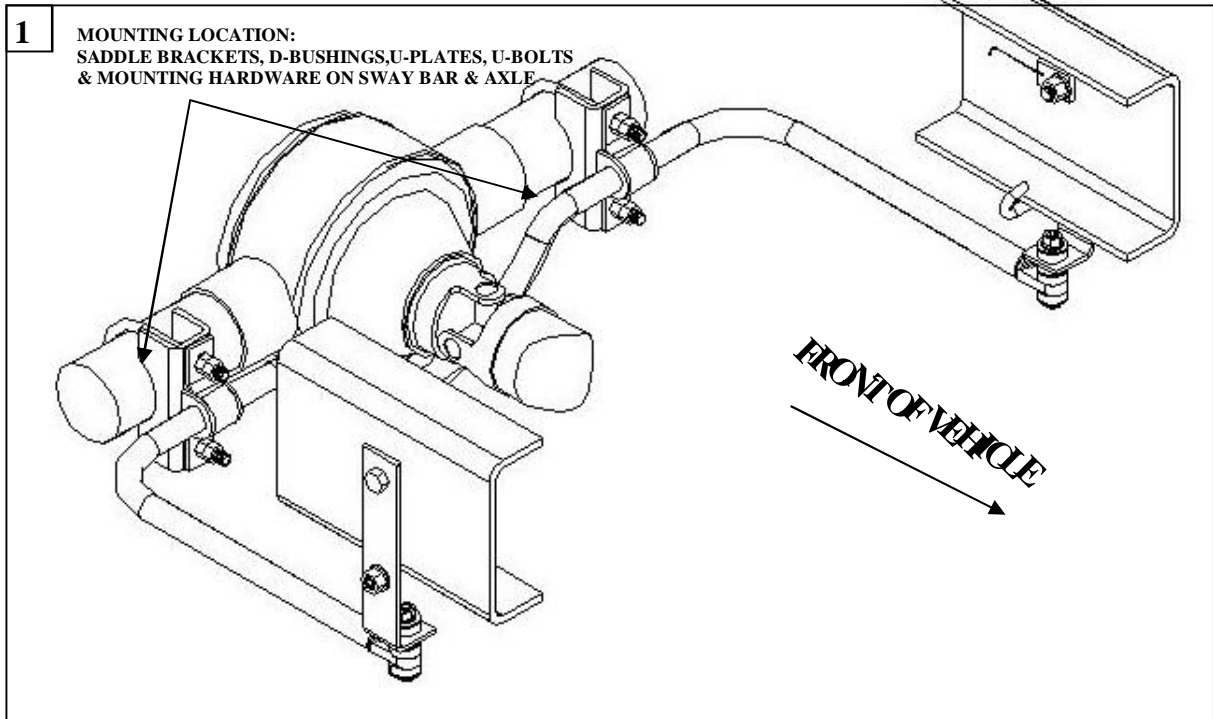



16237 AVENUE 296 . VISALIA, CA 93292
TEL. (559) 734-7451 1-800-435-5977 FAX (559) 734-7460

TORQUE TABLE

BOLT SIZE: 3/8" = 20-30 ft. lbs. – 7/16" = 35-45 ft. lbs. – 1/2" = 50-70 ft. lbs. – 9/16" = 70-90 ft. lbs.

SAFETY: BEFORE STARTING YOUR INSTALLATION, BE SURE TO SET PARKING BRAKE AND CHOCK TIRES.

NOTE: TO EASE INSTALLATION AND TO PROPERLY ADJUST BAR, THE WEIGHT OF THE VEHICLE MUST BE ON THE SUSPENSION, AS IF DRIVING DOWN THE ROAD. DO NOT RAISE VEHICLE BY FRAME.

1. Place the U-bolts on the axle pointing down. Be careful as not to damage the brake line mounted on the axle. Install the D-shaped poly bushings on the flat areas of the sway bar between the center hump and the arms of the sway bar. Attach the saddle brackets to the U-bolts on the axle. Raise the sway bar to the axle, align the D-bushings to match the U-bolts on the axle. Position the U-plates over the D-bushing and attach with the 1/2" hex nuts supplied. **Leave loose at this time to allow for adjustment later. (SEE PHOTO (1) FOR ASSEMBLY).**
2. On the vehicles frame locate the pre-drilled holes. Attach the angle frame brackets to the frame with the mounting hardware provided. On the inside of the frame the threaded plate with attached wire (**pigtail**) will be used. (Note on some applications a hex nut can be used). Be careful as to not damage or crimp any electrical wires or brake lines that run thru the frame rail. Locate the J-bolts, with the hooked end hook the bottom lip of the vehicles frame insert threaded end thru the hole on the angle frame bracket. Attach with mounting hardware provided. **Leave loose at this time to allow for adjustment later. (SEE PHOTOS (2&3).** Do the same on opposite frame.
3. Attach the end link assemblies to the sway bar. End link bolt, flat washer, round poly-bushing, insert thru hole of arm on the sway bar, bushing, flat washer, bushing. Raise the sway bar up to the angle frame brackets. Insert end link assembly thru hole on frame bracket, install bushing, flat washer and lock nut. Do the same on opposite end. **Leave loose to allow for adjustment later. (SEE PHOTO (3).**
4. With the sway bar centered at the axle and the end link assemblies straight up and down as possible torque all mounting hardware to specified rates.
5. Bounce the vehicle, checking for clearance on all undercarriage components, exhaust, shocks, brake and fuel lines. Test drive the vehicle, re-check your installation re-adjust and torque as required. Re-check your installation on a monthly regular basis thereafter.

ATTENTION INSTALLER: BE SURE THAT THE CUSTOMER RECEIVES THIS INSTRUCTION SHEET, ALL IMPORTANT NOTE CARDS AND THE WARRANTY FORM



16237 AVENUE 296 . VISALIA, CA 93292
TEL. (559) 734-7451 1-800-435-5977 FAX (559) 734-7460

PARTS LIST

RSB KIT # 7587

PART #	QTY	DESCRIPTION
20217587	1	1-1/8" SWAY BAR
20907587	1	COMPLETION KIT
111000486	2	1-1/8" POLY BUSHING
20800378	2	U-PLATE
20800761	2	SADDLE BRACKET
20800162	2	ANGLE BRACKET
20800695	2	J-BOLT
20800342	2	THREADED PLATE
118000156	2	1/2" X 3-5/8" X 6-1/2" ROUND U-BOLT
125030336	1	BUSHING BAG # BG-336
111000389	8	END LINK BUSHING
125020274	1	SMALL APRTS BAG # BG-274
107401042	4	7/16" LOCK NUT
102520043	4	1/2" FLAT WASHER
20800534	4	1/4" X 1" X 1" SQUARE SPACER
101500013	4	3/8" X 1-1/2" CAP SCREW
102306001	6	3/8" FLAT WASHER
102400023	10	7/16" FLAT WASHER
105521044	8	1/2" HEX NUT
101500027	2	7/16" X 3-1/4" CAP SCREW
135000369	1	INSTRUCTION SHEET (R-369)

7587 (R-369)

03/06/07